

$\lambda 2$ – Image Splitter

Product Information



akrima
imaging solutions

akrima GmbH
Rheinstraße 4
6971 Hard
Austria

web: www.akrima.at
mail: info@akrima.at
tel.: +43 664 1480441





The $\lambda 2$ -Image Splitter is a dual-channel image splitting optical device for fluorescence microscopy, designed to simultaneously capture images of two different channels (e.g. wavelengths) on a single camera sensor. This solution removes the complexity and need for using multiple cameras and circumvents the low temporal resolution issues associated with sequential imaging.

The $\lambda 2$ is engineered for precision and ease of use, ensuring maximum comfort for daily users. Its setup and alignment can be completed in just a few minutes, and its intuitive operation simplifies the workflow.

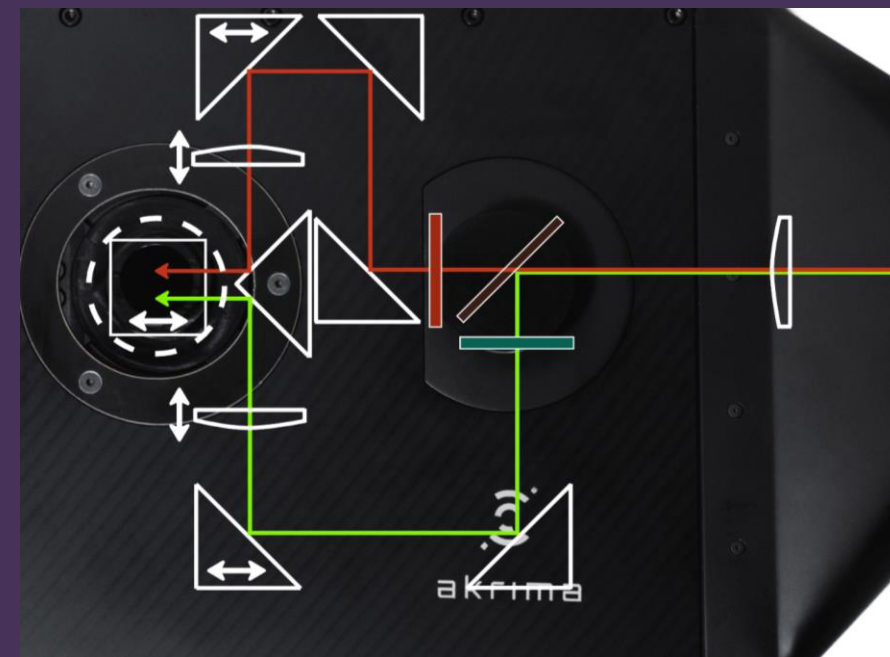

Usability



- ✓ Image Splitting and Bypass for full chip imaging
- ✓ Setup and alignment in just a few minutes
- ✓ Tool-free setup and daily use
- ✓ User-friendly and intuitive handling
- ✓ High quality components and materials
- ✓ Minimal distortion because of central passing through optical elements

Unique features

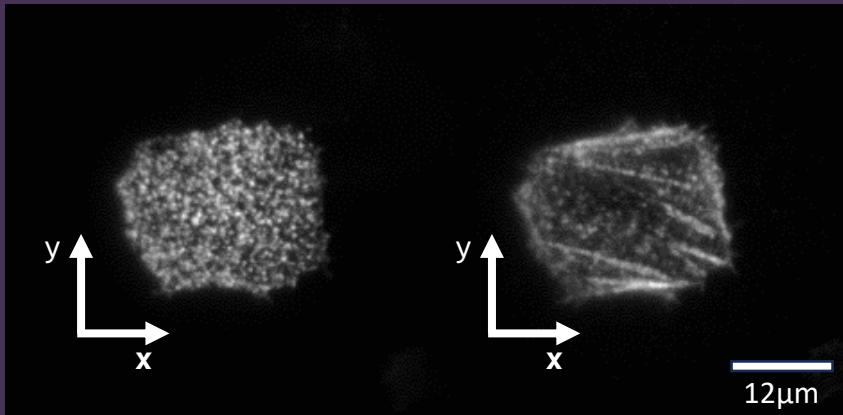

Actin filament (right) and ErbB4 (left) staining in HeLa cells. Actin filaments were stained with Phalloidin-Alexa Fluor 647; ErbB4 was stained with mouse monoclonal ErbB4-antibody / goat anti-mouse IgG Abberior STAR 488. Imaged with λ2-Prototype.

- ✓ True spatial separation and separate lenses for each channel
 - Correct chromatic aberration
 - Offers the possibility for off-focus imaging (3D information)
- ✓ Quick-release camera mount
 - Easy and fast way to mount camera
 - Camera weight supported by solid aluminum body
 - Space-saving camera mounting
 - Change between cameras (e.g. EMCCD to (s)CMOS)
 - Free rotation of camera chip for high-speed acquisition

Properties



akrma
imaging solutions

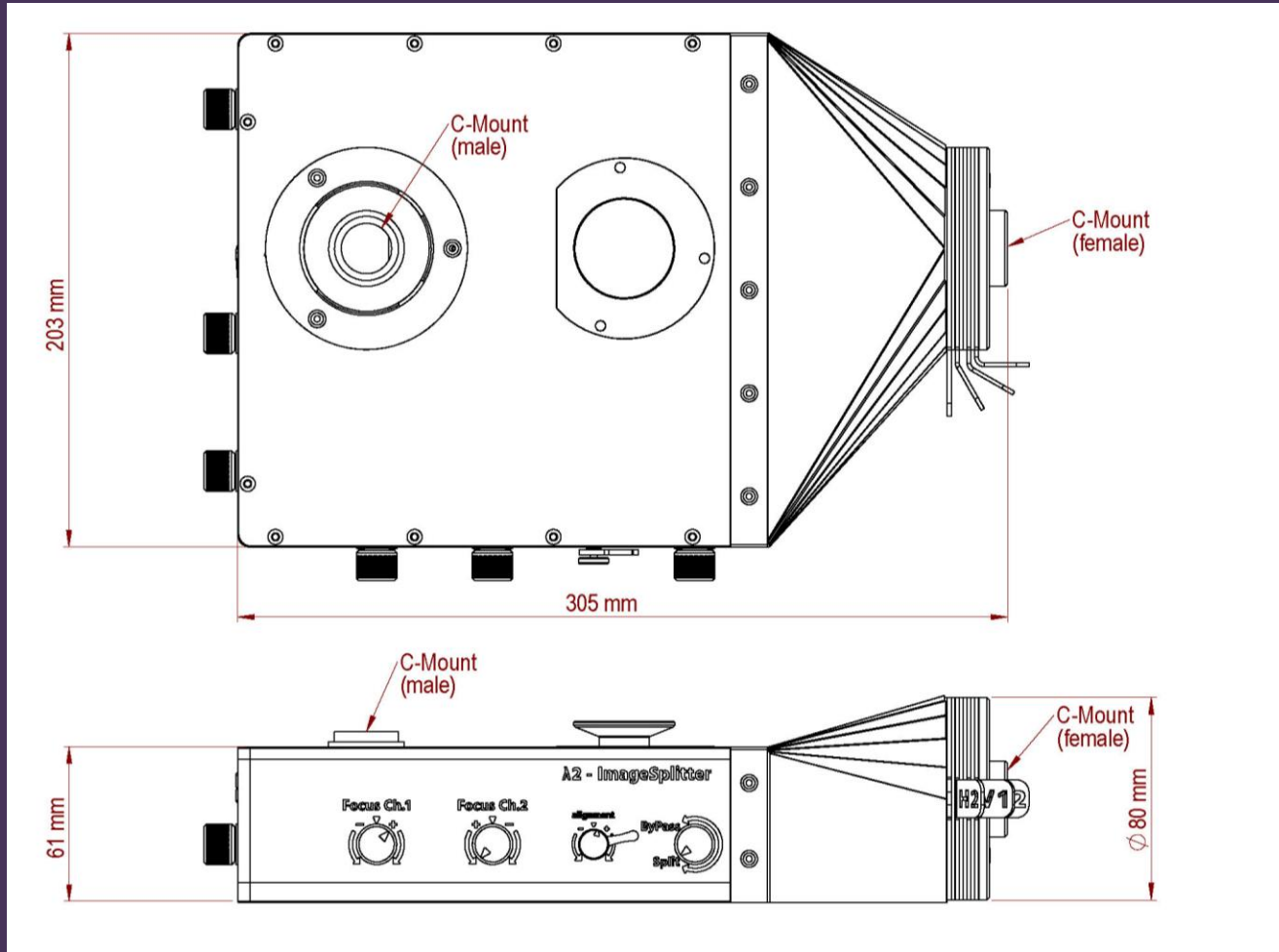

- Compatible with standard 25mm emission filters and 25,2mm x 36,6mm dichroic mirrors (1mm to 3mm thickness with option for individual dimensions)
- FoV: 1" optics throughout the device; the max. FoV (in ByPass mode) is limited by the C-mount itself (20mm diameter); Aperture opening 25mm x 25mm;
- 4f-system with AR (vis) coated lenses
- Dielectric mirrors (avg. reflectance >99% at 400-750nm)

Impressions



Impressions



akrimea
imaging solutions

